

# GUHRING

NEW

THE PRODUCTION SOLUTION  
FOR HIGH-PRECISION  
MICRO-THREADS FROM  
DIAMETER M1.0



**Micro-fluteless taps and micro-thread milling cutters**

GUHRING - YOUR WORLD-WIDE PARTNER

MICRO-FLUTELESS TAPS AND MICRO-THREAD MILLING CUTTERS

MICRO-FLUTELESS TAPS



# GUHRING MICRO-FLUTELESS TAPS AND THREAD MILLING CUTTERS FOR THE RELIABLE PRODUCTION OF HIGH QUALITY THREADS

- ⇒ **THREAD SIZES FROM M1 AS STANDARD TOOLS**
- ⇒ **HIGHLY ACCURATE, PERFECTLY FINISHED THREADS**
- ⇒ **VERSATILE APPLICATION INCLUDING UNIVERSAL MACHINING AND HIGHER-STRENGTH MATERIALS**

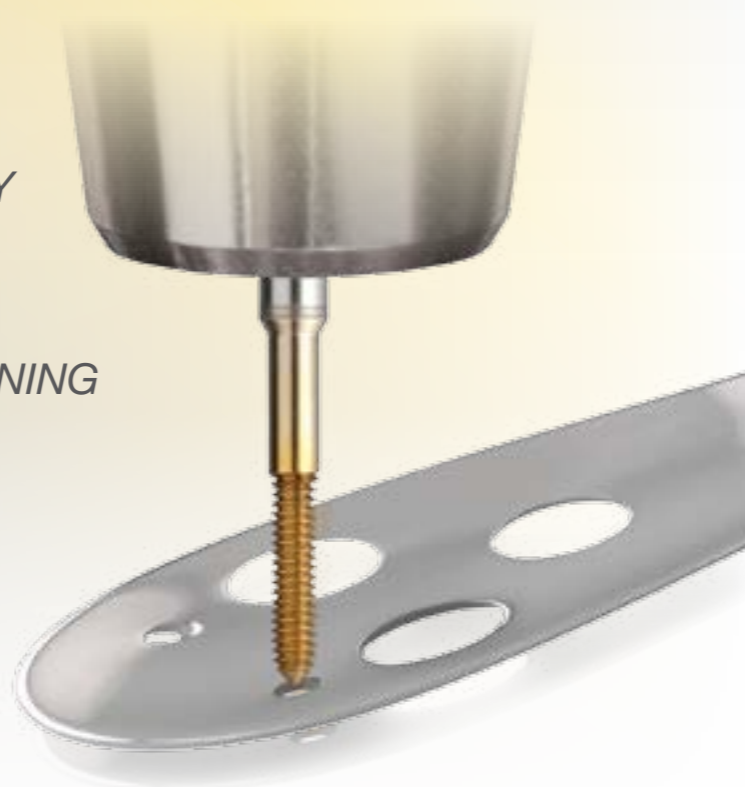

## Micro-fluteless taps for ISO metric threads

<b>Guhring no.</b>	<b>921</b>
<b>Standard</b>	<b>DIN 2174</b>
<b>Standard</b>	<b>~ DIN 371</b>
<b>Tool material</b>	<b>HSS-E</b>
<b>Surface finish</b>	<b>S</b>
<b>Type</b>	<b>N</b>
<b>Form</b>	<b>C</b>
<b>Tolerance</b>	<b>6HX</b>
<b>Cutting direction</b>	<b>right-hand</b>
<b>Discount group</b>	<b>103</b>

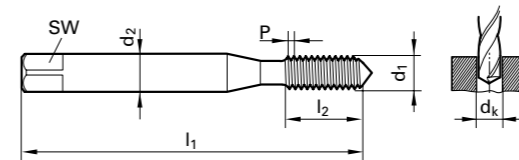

d1	P	d2	SW	dk	l1	l2
	mm	mm		mm	mm	mm
M 1	0.25	2.50	2.10	0.90	40.00	4.00
M 1.2	0.25	2.50	2.10	1.10	40.00	4.80
M 1.4	0.3	2.50	2.10	1.28	40.00	5.60
M 1.6	0.35	2.50	2.10	1.46	40.00	6.40
M 1.7	0.35	2.50	2.10	1.55	40.00	6.80
M 1.8	0.35	2.50	2.10	1.66	40.00	7.20



Availability	
●	
●	
●	
●	
●	
●	

### TAPPING SIZE HOLE DIAMETER

With fluteless tapping, the tapping size hole diameter influences the distinction of the formed thread. A too small tapping size hole diameter results in an over-forming of the thread which must definitely be prevented because this can lead to tool breakage. A too large tapping size hole is acceptable with certain tolerances because formed threads have a sufficient loading capacity from a 50% bearing depth.

Tapping size hole diameter is too large:

- thread not formed
- large form pocket (claw)
- height of profile too low

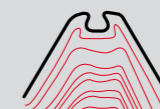

Optimal tapping size hole diameter:

- thread fully formed
- small form pocket (claw)
- optimal height of profile

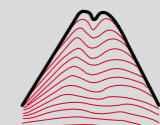

Tapping size hole too small:

- thread over-formed
- no form pocket (claw)
- profile too high

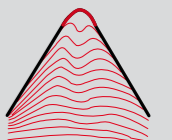

### HOLE Ø THREAD FORMING

ISO metric threads DIN 13

nom. Ø	pitch P	hole Ø
M 1	0.25	0.90
M 1.2	0.25	1.10
M 1.4	0.30	1.28
M 1.6	0.35	1.46
M 1.7	0.35	1.55
M 1.8	0.35	1.66

Drills in the following dimensions are available in Guhring's standard range for the production of holes:



Guhring no. 301, DIN 1899, HSS-E-PM, bright



Guhring no. 6400, Guhring Standard, solid carbide, TiAlN SuperA

MICRO-FLUTELESS TAPS

Micro-fluteless taps for ISO metric threads

Guhring no.	1016	1017
Standard	JIS B 4430	JIS B 4430
Standard	-	-
Tool material	HSS-E	HSS-E
Surface finish	○	Ⓢ
Type	N	N
Form	C	C
Tolerance	RH4	RH4
Cutting direction	right-hand	right-hand
Discount group	103	103

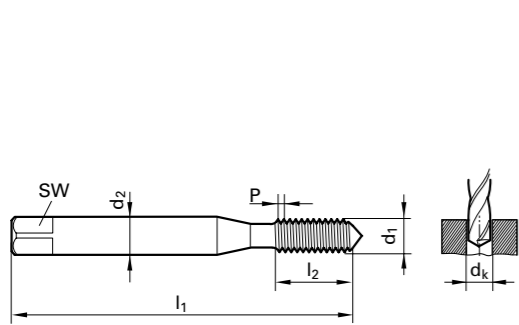

d1	P	d2	SW	dk	l1	l2
mm	mm	mm	mm	mm	mm	mm
M 1	0.25	3.00	2.50	0.90	36.00	4.00
M 1.2	0.25	3.00	2.50	1.10	36.00	4.80
M 1.4	0.3	3.00	2.50	1.28	36.00	5.60
M 1.6	0.35	3.00	2.50	1.46	36.00	6.40
M 1.7	0.35	3.00	2.50	1.55	36.00	6.80
M 1.8	0.35	3.00	2.50	1.66	36.00	7.20

Availability	
●	●
●	●
●	●
●	●
●	●
●	●

MICRO-THREAD MILLING CUTTERS

Micro-thread milling cutters MTM 3 SP M

Standard	Guhring Standard
Tool material	Solid carbide
Carbide grade	K/P
Surface finish	Ⓢ
Type	SP M
Thread depth	3xD
Shank form	HA
Cutting direction	right-hand
Discount group	108

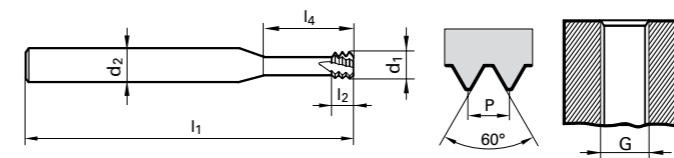

G	P	d1	d2 h6	l1	l2	l4	Z	Order no.
	mm	mm	mm	mm	Gang	mm		
M1.6	0.35	1.20	3.00	39.00	3	4.80	3	302 715 077
M1.8	0.35	1.40	3.00	39.00	3	5.40	3	302 715 078
M2	0.4	1.55	3.00	39.00	3	6.00	3	302 715 079
M2.2	0.45	1.70	3.00	39.00	3	6.60	3	302 715 080
M2.5	0.45	2.00	3.00	39.00	3	7.50	3	302 715 081
M3	0.5	2.40	6.00	58.00	3	9.00	3	302 715 083
M3.5	0.6	2.80	6.00	58.00	3	10.50	3	302 715 084
M4	0.7	3.20	6.00	58.00	3	12.00	3	302 715 085
M5	0.8	4.00	6.00	58.00	3	15.00	4	302 715 086
M6	1	4.80	6.00	58.00	3	18.00	4	302 715 087

Availability
●
●
●
●
●
●
●
●
●
●

COOLING LUBRICANTS WITH FLUTELESS TAPS

With fluteless taps the main task of the coolant is lubrication. The better the lubrication with the maximum concentration, the longer the tool life. There are two different types of lubricant:

Oil based lubricants

These are mineral oils with the best lubricating characteristics. They reduce friction and achieve optimal life.

Soluble lubricants

Soluble (water based) lubricants are thinned to the required concentration level. The concentration must not be below 6%. A content more than 12% is ideal in order to achieve a long life thanks to a good lubrication effect.

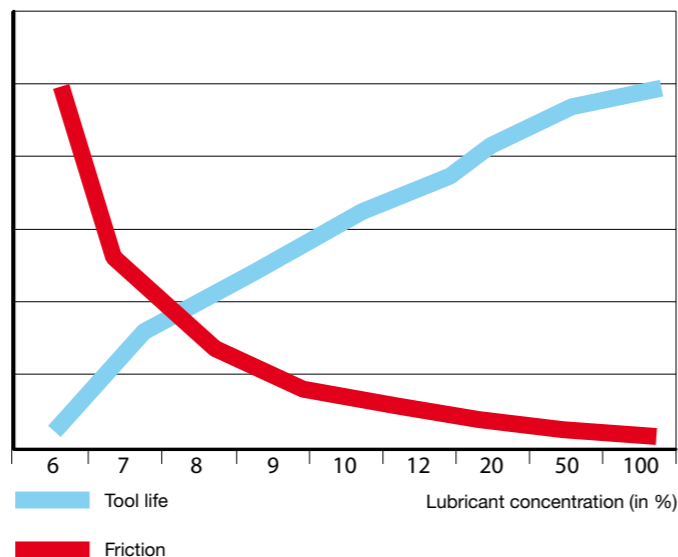

MICRO-THREAD MILLING CUTTERS

Solid carbide micro-thread milling cutters have been specially developed for the production of threads in small holes:

- Excellent characteristics in higher-strength materials (i.e. titanium alloys, stainless steels, ....)
- Blind holes and through holes up to 3xD
- Minimum cutting force
- Very good thread quality
- Short machining times



MICRO-THREAD MILLING CUTTERS

MICRO-THREAD MILLING CUTTERS

Micro-thread milling cutters MTM 1 SP M\*

Standard	Guhring Standard
Tool material	Solid carbide
Carbide grade	K/P
Surface finish	Ⓢ
Type	SP M*
Thread depth	3xD
Shank form	HA
Cutting direction	right-hand
Discount group	108

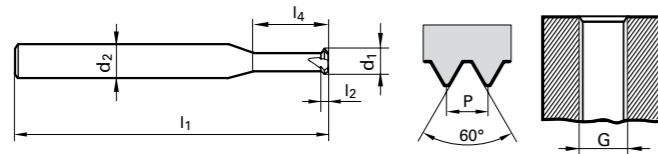

G min.	P max.	d1	d2 h6	l1	l2	l4	Z	Order no.
	mm	mm	mm	mm	Gang	mm		
M1.4-M1.8	0.35	1.05	3.00	39.00	1	5.50	3	302 715 088
M2-M2.4	0.4	1.55	3.00	39.00	1	7.00	3	302 715 089
M2.5-M3	0.5	2.00	3.00	39.00	1	9.00	3	302 715 090
M3.5-M4.5	0.75	2.80	6.00	58.00	1	14.00	3	302 715 091
M5-M7	1	4.00	6.00	58.00	1	19.00	4	302 715 092
M8-M10	1.5	6.40	8.00	64.00	1	24.00	5	302 715 093

Availability
●
●
●
●
●
●

\* universal application, different nominal diameters with different pitches (P<sub>max</sub>)

GEOMETRY COMPARISON

Guhring's micro-thread milling cutters are available in a 3-tooth as well as in a 1-tooth design. While the 3-tooth design firmly dictates the thread size and pitch, the 1-tooth design allows the universal production of threads with different nominal diameters in the specified diameter range with different pitches up to the specified P<sub>max</sub>-value. Therefore, for example the 1-tooth thread milling cutter M2.5 – M3, P<sub>max</sub> 0.5 mm, is applicable for all types of thread combinations from M2.5 x 0.35 to theoretically M10 x 0.5.



RECOMMENDATIONS FOR MICRO-THREAD MILLING CUTTERS

Material group	Cutting speed v <sub>c</sub> (m/min)	Feed mm /per tooth fz for Ø													
		Milling cutter Ø													
		Ø1	Ø1.5	Ø2	Ø3	Ø4	Ø5	Ø6	Ø7	Ø8	Ø9	Ø10	Ø12	Ø14	
Structural steels	70 - 120	0.04	0.04	0.05	0.05	0.06	0.06	0.07	0.07	0.08	0.09	0.09	0.1	0.12	
Free-cutting steels	70 - 120	0.04	0.04	0.05	0.05	0.06	0.06	0.07	0.07	0.08	0.09	0.09	0.1	0.12	
Unalloyed case hardened steels	70 - 120	0.04	0.04	0.05	0.05	0.06	0.06	0.07	0.07	0.08	0.09	0.09	0.1	0.12	
Unalloyed heat-treatable steels	70 - 120	0.04	0.04	0.05	0.05	0.06	0.06	0.07	0.07	0.08	0.09	0.09	0.1	0.12	
Alloyed case hardened steels	60 - 90	0.03	0.03	0.04	0.04	0.05	0.05	0.06	0.06	0.07	0.07	0.08	0.09	0.1	
Alloyed heat-treatable steels	60 - 90	0.03	0.03	0.04	0.04	0.05	0.05	0.06	0.06	0.07	0.07	0.08	0.09	0.1	
Alloyed tool steels	60 - 90	0.03	0.03	0.04	0.04	0.05	0.05	0.06	0.06	0.07	0.07	0.08	0.09	0.1	
Stainless-/acid-resist. steels: sulphured	40 - 80	0.02	0.02	0.02	0.03	0.03	0.04	0.05	0.05	0.05	0.06	0.06	0.06	0.07	
	austenitic	40 - 80	0.02	0.02	0.02	0.03	0.03	0.04	0.05	0.05	0.05	0.06	0.06	0.06	0.07
	martensitic	40 - 80	0.02	0.03	0.03	0.04	0.04	0.05	0.05	0.05	0.06	0.07	0.07	0.08	0.09
Grey cast, Cast iron	60 - 80	0.04	0.04	0.05	0.05	0.06	0.06	0.07	0.07	0.08	0.09	0.09	0.1	0.12	
Spheroidal graphite iron	60 - 80	0.04	0.04	0.05	0.05	0.06	0.06	0.07	0.07	0.08	0.09	0.09	0.1	0.12	
Malleable cast iron	60 - 80	0.04	0.04	0.05	0.05	0.06	0.06	0.07	0.07	0.08	0.09	0.09	0.1	0.12	
Aluminium and Al-alloys	80 - 150	0.04	0.05	0.05	0.06	0.06	0.07	0.07	0.08	0.09	0.1	0.11	0.12	0.14	
Non-ferrous metals, copper alloys	80 - 150	0.04	0.05	0.05	0.06	0.06	0.07	0.07	0.08	0.09	0.1	0.11	0.12	0.14	
Plastics	60 - 200	0.05	0.05	0.06	0.07	0.07	0.08	0.09	0.09	0.1	0.11	0.12	0.13	0.15	
Special alloys and titanium	20 - 40	0.02	0.02	0.02	0.03	0.03	0.04	0.05	0.05	0.05	0.06	0.06	0.06	0.07	

PROGRAMMING EXAMPLE: ( M3X(0.5) MTM3 SP M 3XD )

Tool material: TiAl6V4  
 Tensile strength: R<sub>m</sub> = 1000 N/mm<sup>2</sup>  
 Blind hole: M3x(0.5)  
 Thread depth: 2.5xD  
 Cutting speed: v<sub>c</sub> = 40 m/min  
 Feed: f<sub>z</sub> = 0.025 mm  
 Processing sequence:  
 synchronous milling

N10 M6 T1  
 N20 G90 G54 G00 X0 Y0  
 N30 Z2 S5305 M3 M8  
 N40 Z-7.50  
 N50 G91  
 N60 G41 G01 X0 Y1.200 F42 (F199)  
 N70 G03 X0 Y-2.725 I0 J-1.363 Z0.075  
 N80 G03 X0 Y0 I0 J1.525 Z0.500 F85 (F398)  
**Number of repetitions of set N80 = 16**  
 N90 G03 X0 Y2.725 I0 J1.363 Z0.075  
 N100 G40 G01 X0 Y-1.200  
 N110 G90  
 N120 G00 Z2 M9  
 N130 M30

COMPARISON TABLE MICRO-THREAD MILLING CUTTERS AND TAPS

Properties	micro-thread milling cutters	tap
Surface quality	high	medium
Thread geometry	very precise	medium
Thread tolerance	4h,5h,6h,6g with standard milling cutters	6h standard, 4h special tool
Processing time	faster than tap	fast
Drive power	very low	high
Tool breakage	almost impossible	easier
Milling cutter diameter range	the same milling cutter for different milling cutter Ø with equal pitch	special tap necessary for each diameter
right-hand or left-hand threads	the same milling cutter for both threads	right-hand tap or left-hand tap

DRILLING

TAPPING/  
THREAD MILLING/  
THREAD FORMING

MILLING

REAMING

PCD



SPECIAL  
SOLUTIONS

COUNTERSINKING

TOOL HOLDERS

SERVICES

# GUHRING

**Guhring oHG**

P.O. Box 100247 • 72423 Albstadt  
Herderstraße 50-54 • 72458 Albstadt

Tel. +49 74 31 17-0  
Fax +49 74 31 17-21279  
info@guehring.de  
www.guehring.de

No liability can be accepted for printing errors or technical changes of any kind. All products marked with "DIN", deviating from the dimensions listed in the catalogue, can be delivered, as long as they are in conformity with the DIN standard form. Our Conditions of Sale and Terms of Payment apply. Available on request.

